

ENCORE[®]
SERIES

INSTALLATION & OPERATING MANUAL

PN 99168

SERVICE NON-REFRIGERATED BAKERY MERCHANDISER

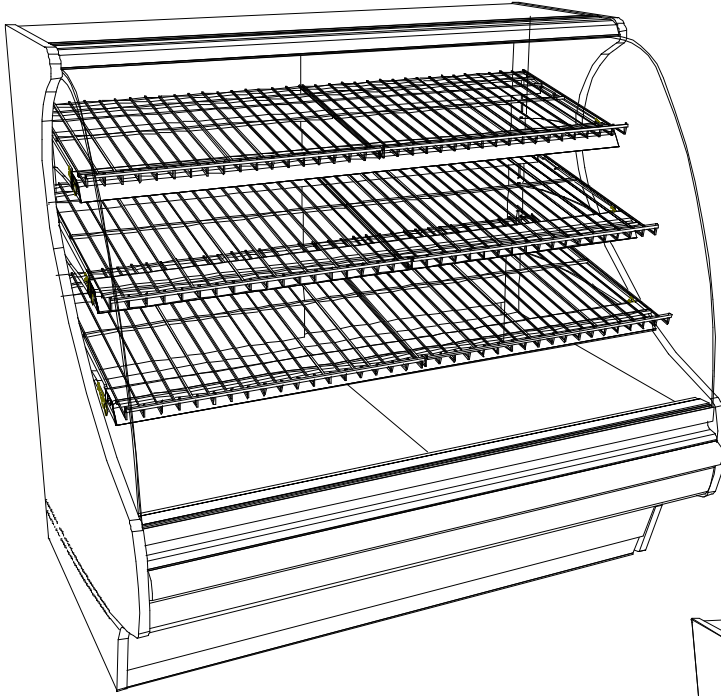

Model HV48
Standard Display Case
4 Display Levels [3 Wire Rack
Shelves and 1 Bottom Deck]

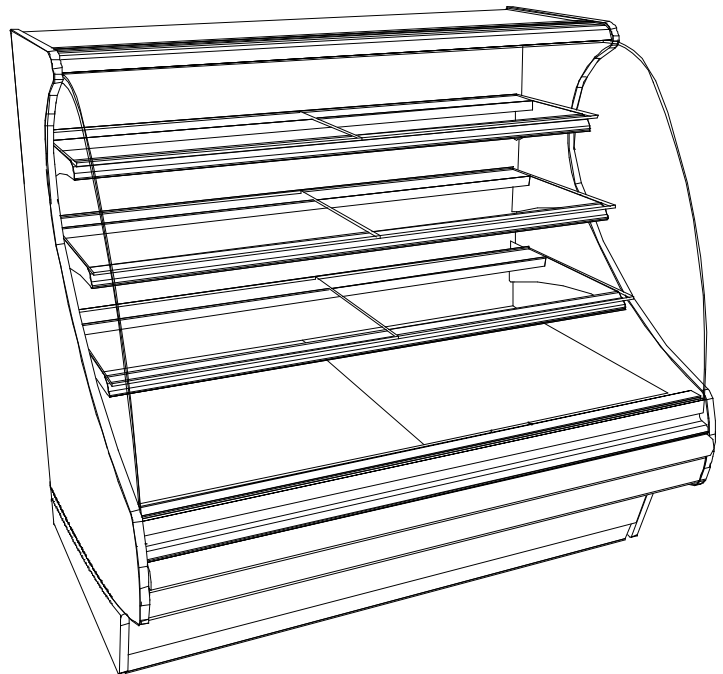

Model HV48
Optional Display Case
4 Display Levels [3 Glass Shelves
and 1 Bottom Deck]

Model HV38	38" L* x 40" D x 50 1/4" H
Model HV48	48" L* x 40" D x 50 1/4" H
Model HV56	56" L* x 40" D x 50 1/4" H
Model HV74	74" L* x 40" D x 50 1/4" H

**Without 7/8" end panels.*



Structural

Concepts

888 E. Porter Rd. Muskegon, MI 49441 Phone: 231.798.8888 Fax: 231.798.4960 www.structuralconcepts.com

TABLE OF CONTENTS

OVERVIEW AND WARNINGS	3
REMOVAL FROM SKID, POSITIONING & LEVELING	4
START-UP AND OPERATION	5-6
MAINTENANCE FUNDAMENTALS	7-8
SERIAL LABEL & LOCATION / TECHNICAL INFORMATION / ADD'L INFORMATION	9
CLEANING SCHEDULE (TO BE PERFORMED BY STORE PERSONNEL)	10
TROUBLESHOOTING	11
ILLUSTRATED PARTS BREAKDOWN	12
PARTS LIST	13
TECHNICAL SERVICE CONTACT INFORMATION & WARRANTY INFORMATION	14

OVERVIEW AND WARNINGS

OVERVIEW

- The Structural Concepts Encore service non-refrigerated cases are designed to merchandise unpackaged bakery products at ambient temperatures.
- These cases should be installed and operated according to the following instructions to insure proper performance.
- This unit is designed for the display of products in ambient store conditions where temperatures and humidity are maintained at a maximum of 75° F and 55% relative humidity.



WARNING
Risk of Electric Shock.
Disconnect Power Before Servicing Unit



CAUTION
Lamps have been treated to resist breakage and must be replaced with a similarly treated lamp.

REMOVAL FROM SKID, POSITIONING & LEVELING

1. Remove Unit From Skid

- Remove case from skid and place into proper position.
- To prevent damage, support case while sliding skid out from under case.
- *Note: Illustration at right reflects general outline of sample case and does not reflect any particular model or options).*

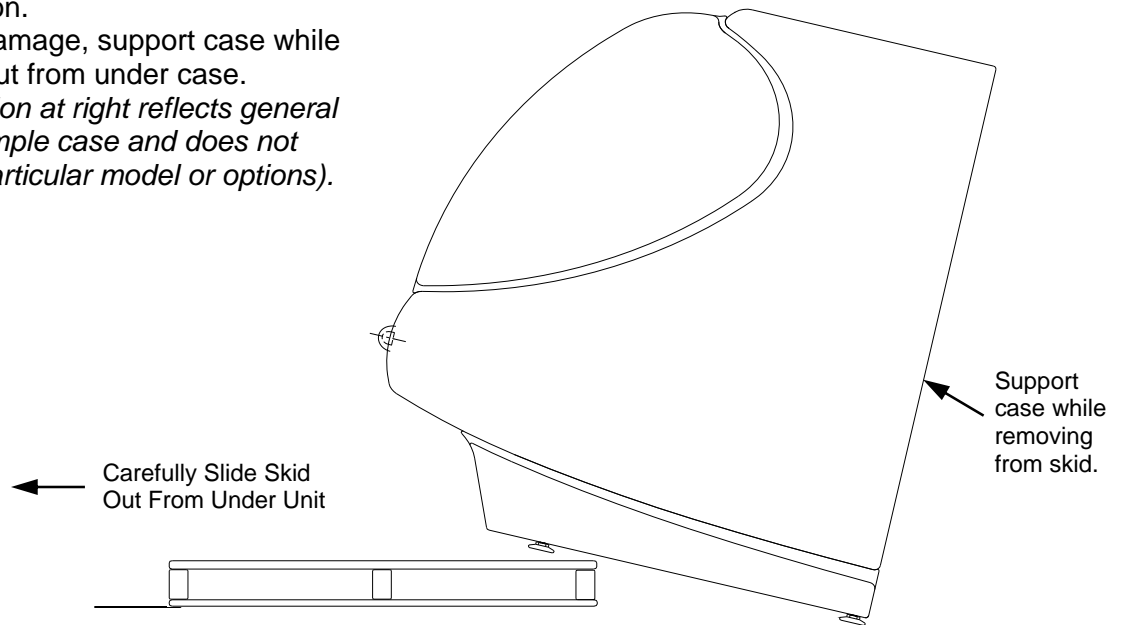

2. Position & Align Case Alongside Other Cases

- Before adjusting levelers, make certain that the case is in proper position and, if required, aligned with adjoining case(s).
- This may require the repositioning of the case you are installing or the already positioned case(s).

3. Adjust Levelers

- After case is in proper position, adjust case so it is level and plumb (see illustration at right).
- You may need to remove front and/or rear Toe-Kick to access levelers.
- Use adjustable wrench to adjust leveler.
- Depending upon case weight it may be necessary to use a Pry Bar to accomplish this task.
- Do not use Pry Bar on Toe-Kick as it may buckle.
- Do not use Pry Bar on End Panel as it may chip.
- Use Pry Bar **ONLY** on Base Frame to avoid damaging case.
- See illustration and photos at right.

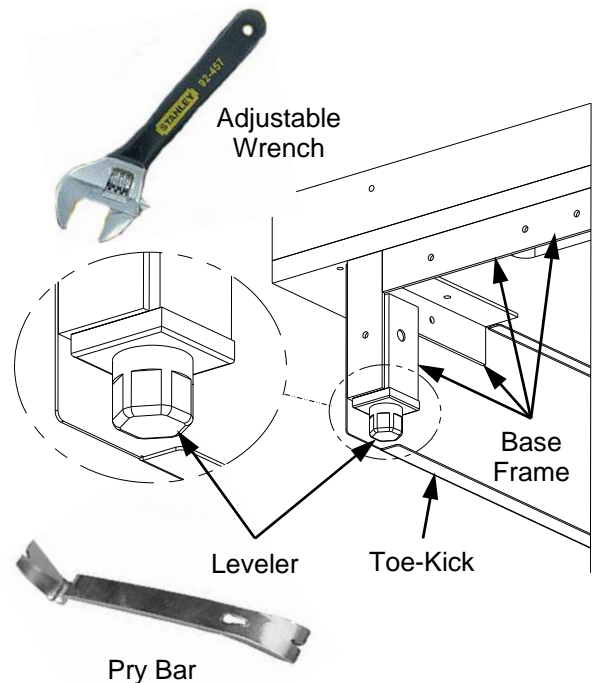

START-UP AND OPERATION

Electrical Access and Connections

Rear Wireway, if used - Remove screws from rear wireway cover to access electrical leads.

- Wiring may run case to case through cut-outs in base.
- Knockout is provided in bottom of wire-way for stub-up connection.
- Separate leads for lights that are labeled accordingly.
- Standard 120 volt, single phase connections is required and should be performed by a certified electrician.

Ballast Box, if used - Remove screws from ballast box cover, rear panel, and ballast box inner support. Knockouts are located on side of box for making electrical connections.

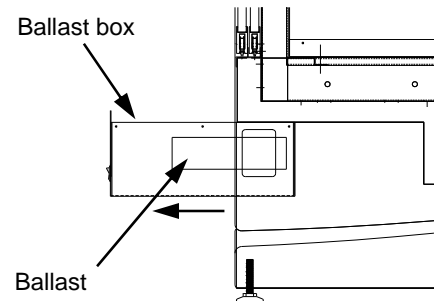
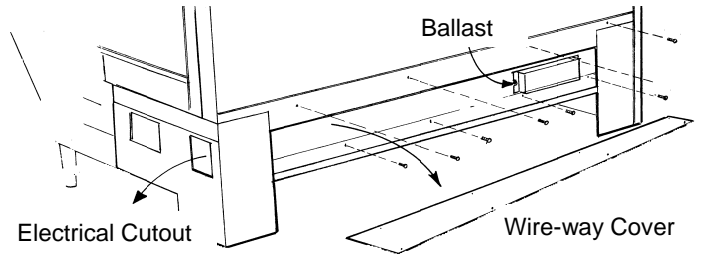

Merchandiser Start-Up

Turn on the lights. All of the lights should come on at the same time. First time lighting may require a short warm up period for the bulbs. Slightly dim or a flickering of new bulbs is normal. If lights do not turn on, check all of the raceway plugs. The lighting is wired in series so **all lights must be plugged in or receptacles capped** in order for the case to light.

Caster Locking Operation (if option chosen)

To lock casters push down on lever, to unlock pull up the lever all the way.

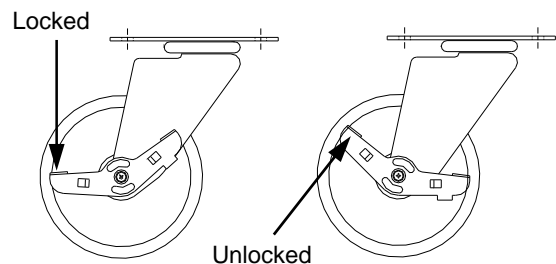
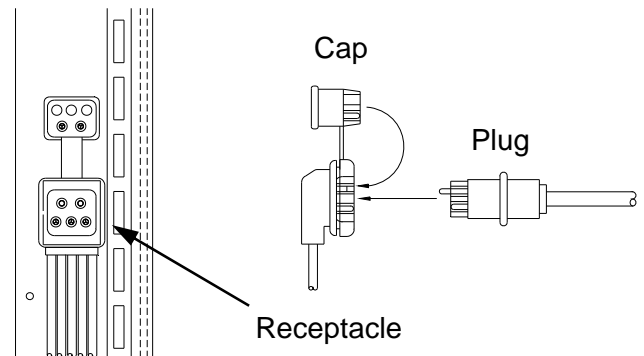
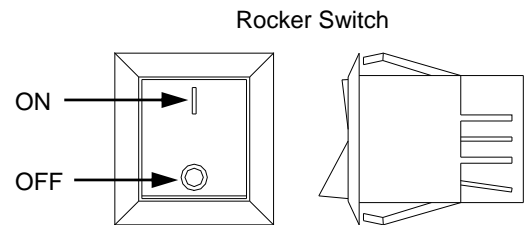

Raise the Curved Glass

- To raise the curved glass, grab the lift handle extrusion on the bottom edge of the front curved glass and lift up.
- Gas cylinders hold the glass open for hands free access to the interior of the case.
- **Note:** When cases are next to a wedge, only one front curved glass may be lifted at a time.

Removing the Rear Doors

- Move the rear doors toward the center of the case.
- Individually lift each door up toward the top of the case and pivot the bottom of the door out.

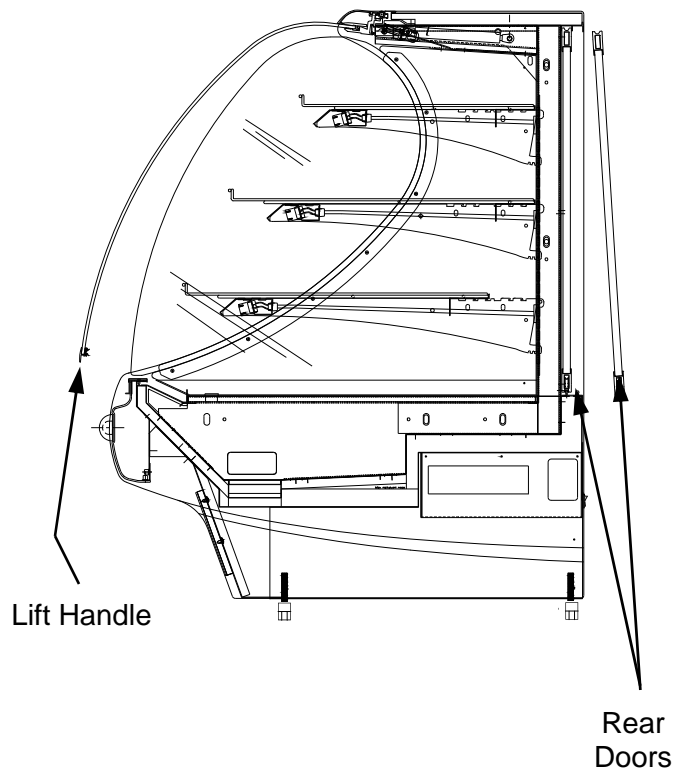

Removal of Upper Front Panel

- Loosen bolt located on the under side of the panel.
- Pull the lower edge of panel out and down.

Adjusting Upper Front Panels

- Remove upper front panel.
- Remove screw caps or a magnetic cover on some units.
- Loosen adjustment screws.
- Adjust front panel supports for alignment to adjacent units and tighten screws & bolts.
- Replace and adjust the lower edge of the upper front panel.

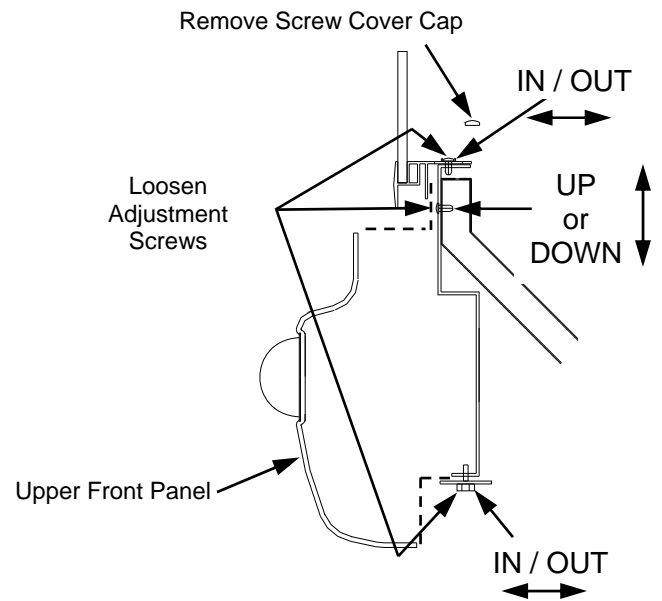

Angled Base Removal

Removal of Lower Front Panel

- Upper panel support.
 - Remove screws located behind the upper front panel.
- Lower panel support.
 - *Most applications*, screws secure the lower panel support, located below front panel, to the unit.
 - **Alternate applications without screws*, applying upward pressure to the lower panel support will disengage the tabs of the lower support panel from slots located in the base at both ends of unit.

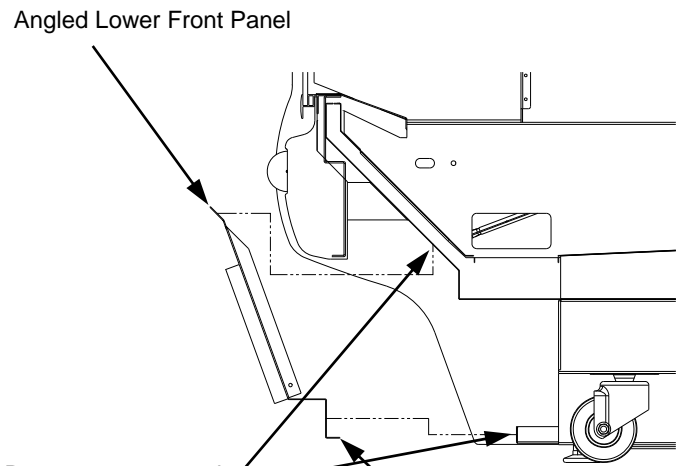

Vertical Base Removal

Removal of Front Panel

- Remove screws located below front glass support channel.
- Lower panel support.
 - *Most applications*, screws secure the lower panel support, located below front panel, to the unit.
 - **Alternate applications without screws*, applying upward pressure to the lower panel support will disengage the tabs of the lower support panel from slots located in the base at both ends of unit.

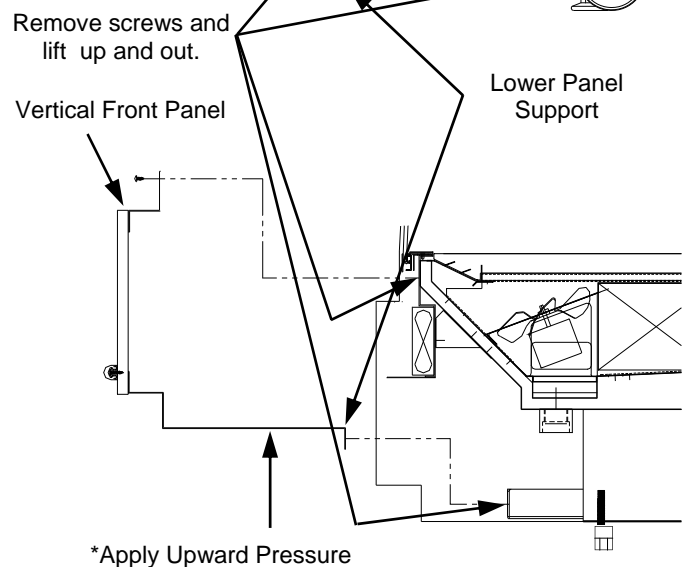

Bracket & Shelf Assembly Removal

- Remove wire rack shelves (standard) or glass shelves (optional).
- For lighted shelving, unplug the light cord.
- Lift shelves straight up to separate from brackets.
- Remove rear rack support / rear shelf support (see illustrations at right).
- Remove brackets. Note: It may be necessary to remove the nylon shipping bracket retainer. Pliers will be required to accomplish this task. See illustration at below right.

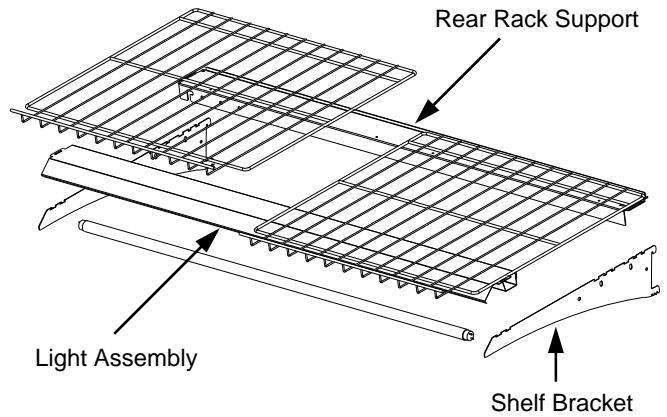

Light Fixture

Removal of lamp:

- Rotate lamp (1/4-turn) either direction to disengage (upper or lower) pins/contacts from lamp mounting sockets.
- Remove bulb by applying even pressure from the back side at the bulb ends and pulling the remaining contact from the sockets.
- See illustration at below-left.

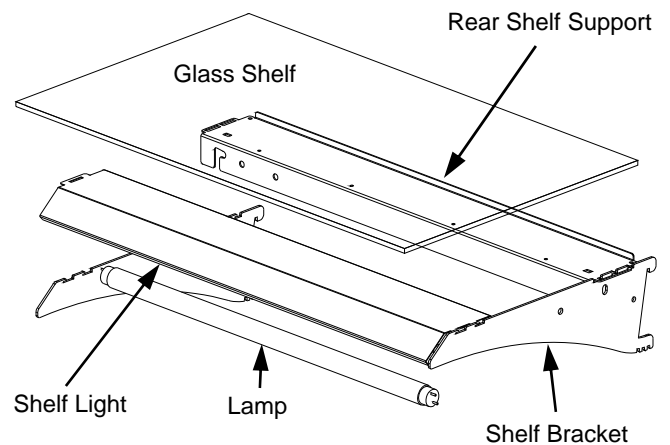



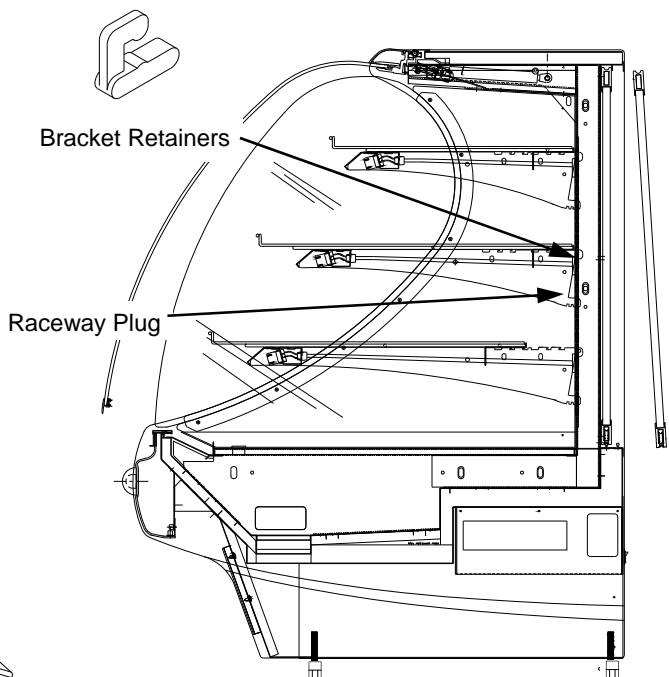
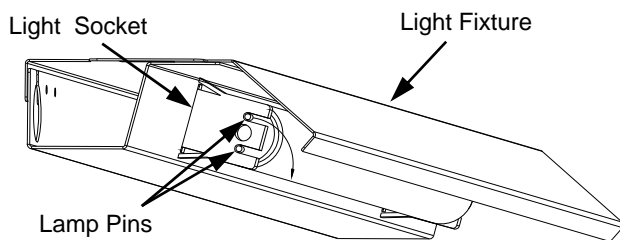

Installation of lamp:

- Align pins with slot.
- Insert pins into socket by rotating the bulb 1/4-turn to secure either the (upper or lower) pined contacts into the sockets.
- Rotate the remaining bulb contacts (1/4 turn) into the remaining lamp mounting socket contacts.
- See illustration at below-left.





Serial Label Information & Location

- Serial labels are located near the electrical access on your case.
- Serial labels contain electrical, temperature & refrigeration information, as well as regulatory standards to which the case conforms.
- For additional technical information, see the *TECHNICAL SERVICE* page in this manual.
- See images below for samples of both refrigerated and non-refrigerated serial labels.

 <p>888 E. Porter Road · Muskegon, MI 49441</p>				<p>MODEL HV74RSS SCROLL SERIAL NO.</p>
<p>FOR PARTS AND SERVICE CALL 1-800-433-9489</p>				
 		<p>ELECTRICAL RATING</p>		<p>120/1/60 24A</p>
<p>3048256</p>		<p>REFRIGERANT</p>		<p>R404A AMOUNT ?? OZ</p>
<p>CONFORMS TO UL STD 471</p>		<p>DESIGN PRESSURE</p>		<p>HIGH 450 LOW 200</p>
<p>CONFORMS TO NSF STD 7</p>		<p>MINIMUM CIRCUIT</p>		<p>30A</p>
<p>CERTIFIED TO CAN/CSA STD C22.2 NO 120</p>		<p>MAXIMUM OVERCURRENT</p>		<p>30A</p>
<p>Super Heat Temp</p>		<p>8-10°F</p>		
<p>BTUH Requirements</p>		<p>9,738 BTUH @ 20° F SST</p>		
<p>Defrost</p>		<p>6 defrosts per day, 45° F termination, 45 min. failsafe</p>		

----- Sample Serial Label For Refrigerated Case -----

 <p>888 E. Porter Road · Muskegon, MI 49441</p>				<p>PC5682 txtRemote txtSerialNumber</p>
		<p>120 VOLTS 60 HZ SINGLE PHASE 1.84AMP</p>		
<p>3048256</p>		<p>FOR PARTS OR SERVICE CALL</p>		
<p>CONFORMS TO UL STD 65</p>		<p>STRUCTURAL CONCEPTS</p>		
<p>CERTIFIED TO CAN/CSA</p>		<p>AT</p>		
<p>STD C22.2 NO 120</p>		<p>1-800-433-9489</p>		
		<p>USA</p>		

SAMPLE ONLY

----- Sample Serial Label For Non-Refrigerated Case -----

CLEANING SCHEDULE (TO BE PERFORMED BY STORE PERSONNEL)

Cleaning	Daily	Weekly	Monthly	Task
Clean Case Exterior	X			Acrylic: Cleaned with a mild soap and water solution and a soft cloth. Never use an household cleaner on acrylic.
	X			Front Curved Glass: Clean with household or commercial glass cleaner and soft cloth or paper towel.
		X		End Panels, Front Panel, Toe-Kick, etc.: Wipe off all surfaces with warm water and mild soap solution and non-abrasive cloth.
			X	Under Case Cleaning: Vacuum under case to remove all dust and dirt that may collect.
Clean Case Interior	X			Wire Rack Shelves: Clean with a household or commercial cleaner or mild soap and water solution and soft cloth or paper towel.
	X			Glass Shelves (Optional) & Side Mirrors: Clean with a household or commercial glass cleaner and soft cloth or paper towel.
		X		Decking: Remove the decking and clean with mild soap and water solution.
		X		Rear Doors and Door Tracks: Remove rear doors and clean with a household or commercial cleaner. While Doors are removed, clean Door Track with same solution.
			X	Warning: Lowering the front glass with fingers or items inside top cap can cause serious injury or damage to case. Raise the front curved glass. Clean inside the cavity at both ends of the hinged top cap with a mild soap and water.

TROUBLESHOOTING

Product is Drying Out	Check the relative humidity in the store.
Doors/Glass Won't Shut Properly	Check the case is aligned, level and plumb.
System is not Operating	Confirm the utility power is on.
	Check the MAIN power switch is on.
	Check the circuit breaker box for tripped circuits.
	If used, check the unit is properly plugged in.
Case Lights Not Working	Be sure ALL lights are plugged in or receptacles capped.
	Check bulb for proper installation and connection.
	Check for burned out bulb.
	Clean dirt and dust from the bulbs to prevent flickering.
	After performing all other checkpoints and lights are still not working, check for faulty ballast. This should be performed by a certified electrician.

ILLUSTRATED PARTS BREAKDOWN

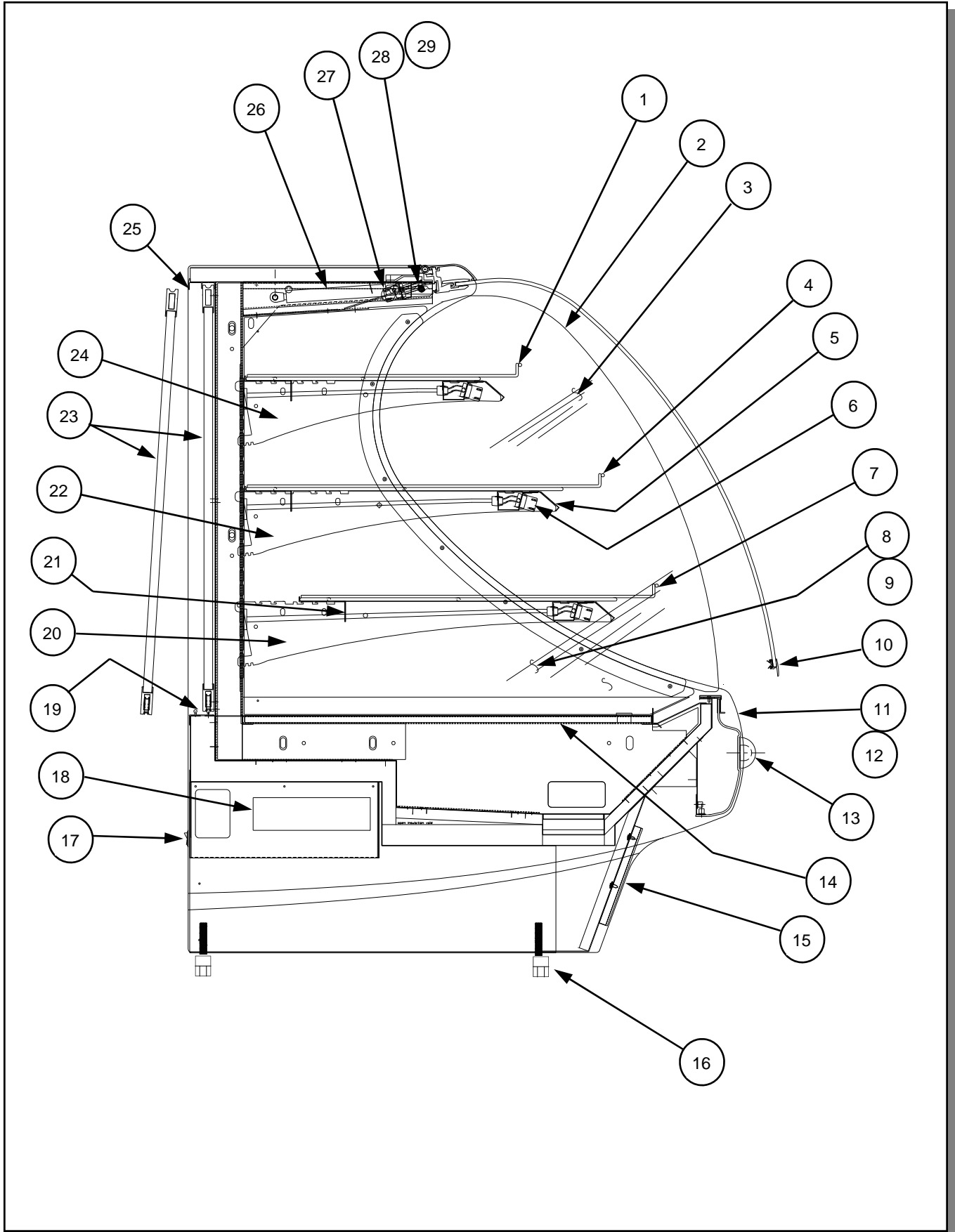

PARTS LIST

1	Wire Shelving, Top	17	Main Power Switch
2	Glass Edge Seal ("Bulb Seal")	18	Ballast
3	Glass End Panel	19	Door Track, Bottom
4	Wire Shelving, Middle	20	Shelving Bracket, Bottom
5	Shelf Light Assembly	21	Support, Shelving
6	Bulb	22	Shelving Bracket, Middle
7	Wire Shelving, Bottom	23	Doors, Sliding
8	End Panel Mirror, LH	24	Shelving Bracket, Top
9	End Panel Mirror, RH	25	Door Track, Top
10	Front Curved Glass Assembly	26	Cylinder, Gas
11	End Panel, LH	27	Light Fixture, Top
12	End Panel, RH	28	Retainer Ring
13	Front Panel Assembly	29	Retainer Pin
14	Decking		
15	Front Panel, Lower		
16	Leveler		

STRUCTURAL CONCEPTS CORPORATION TECHNICAL SERVICE
PHONE NUMBER: 1.800.433.9489 or For Your Master Service Agent See
WWW.STRUCTURALCONCEPTS.COM/Contact/Master_Service_Agents.asp

WARRANTY INFORMATION

(Note: Standard Limited Warranty can be found at www.StructuralConcepts.com)

All sales by Structural Concepts Corporation (SCC) are subject to the following limited warranty. "Goods" refers to the product or products being sold by SCC.

Warranty Scope: Warranty is for equipment sold in the United States, Canada, Mexico and Puerto Rico. Limited warranty may apply to equipment sold elsewhere.

Warranty; Remedies; Limitations. SCC warrants that if any Goods are found by an authorized representative of SCC not to be of good material or workmanship within one year of the date of shipments SCC will, at its option after inspection by an authorized representative, replace any defective Good or pay the reasonable cost of replacement for any such defective Goods, provided that written notice of the defect is given to SCC within 30 days of the appearance of such defect. If notice is not given within such period, any claim for breach of warranty shall be conclusively deemed to have been waived and SCC shall not be liable under this warranty. If SCC is unable to repair or replace the defective Goods, SCC shall issue a credit to the Purchaser for all or part of the purchase price, as SCC shall determine. The replacement or payment in the manner described above shall be the sole and exclusive remedy of Purchaser for a breach of this warranty. If any Goods are defective or fail to conform to this warranty, SCC will furnish instructions for their disposition. No Goods shall be returned to SCC without its prior consent.

SCC's liability for any defect in the Goods shall not exceed the purchase price of the Goods. SCC SHALL HAVE NO LIABILITY TO PURCHASE FOR CONSEQUENTIAL DAMAGES OF ANY KIND WHATSOEVER, INCLUDING, BUT NOT LIMITED TO, PERSONAL INJURY, PROPERTY DAMAGE, LOST PROFITS, OR OTHER ECONOMIC INJURY DUE TO ANY DEFECT IN THE GOODS OR ANY BREACH OF SCC. SCC SHALL NOT BE LIABLE TO THE PURCHASER IN TORT FOR ANY NEGLIGENT DESIGN OR MANUFACTURE OF THE GOODS, OR FOR THE OMISSION OF ANY WARNING THEREFROM.

SCC shall have no obligation or liability under this warranty for claims arising from any other party's (including Purchaser's) negligence or misuse of the Goods or environmental conditions. This warranty does not apply to any claim or damage arising for or cause by improper storage, handling, installation, maintenance, or from fire, flood, accidents, structural defects, building settlement or movement, acts of God, or other causes beyond SCC's control.

Except as expressly stated herein, SCC makes no warranty, express, implied, statutory or otherwise as to any parts or goods not manufactured by SCC. SCC shall warrant such parts or Goods only (I) against such defects, (II) for such periods of time, and (III) with such remedies, as are expressly warranted by the manufacturer of such parts of Goods. Notwithstanding the foregoing, any warranty with respect to such parts of Goods and any remedies available as a result of a breach thereof shall be subject to all of the procedures, limitations, and exclusions set forth herein.

THE WARRANTIES HEREIN ARE IN LIEU OF ALL WARRANTIES, EXPRESS, IMPLIED, STATUTORY, OR OTHERWISE. IN PARTICULAR, SCC MAKES NO WARRANTY OF MERCHANTABILITY OR FITNESS FOR A PARTICULAR PURPOSE.

No representative, agent or dealer of SCC has authority to modify, expand, or extend this Warranty, to waive any of the limitations or exclusions, or to make any different or additional warranties with respect to Goods.

Period of Limitations. No claim, suit or other proceeding may be brought by Purchaser for any breach of the foregoing warranty or this Agreement by SCC or in any way arising out of this Agreement or relating to the Goods after one year from the date of the breach. In the interpretation of this limitation on action for a breach by SCC, it is expressly agreed that there are no warranties of future performance of the goods that would extend that period of limitation herein contained for bringing an action.

Indemnifications. Purchaser agrees to indemnify, hold harmless, and defend SCC if so requested, from any and all liabilities, as defined herein, suffered, or incurred by SCC as a result of, or in connection with, any act, omission, or use of the Goods by Purchaser, its employees or customers, or any breach of this Agreement by Purchaser. Liabilities shall include all costs, claims, damages, judgments, and expenses (including reasonable attorney fees and costs).

Remedies of SCC. SCC's rights and remedies shall be cumulative and may be exercised from time to time. In a proceeding or action relating to the breach of this Agreement by Purchaser, Purchaser shall reimburse SCC for reasonable costs and attorney's fees incurred by SCC. No waiver by SCC of any breach of Purchaser shall be effective unless in writing nor operate as a waiver of any other breach of the same term thereafter. SCC shall not lose any right because it has not exercised it in the past.

Applicable Law. This Agreement is made in Michigan and shall be governed by and interpreted according to Michigan law. Any lawsuit arising out of this Agreement or the Goods may be handled by a federal or state court whose district includes Muskegon County, Michigan, and Purchaser consents that such court shall have personal jurisdiction over Purchaser.

Miscellaneous. If any provision of this Agreement is found to be invalid or unenforceable under any law, the provision shall be ineffective to that extent and for the duration of the illegality, but the remaining provisions shall be unaffected. Purchaser shall not assign any of its rights nor delegate any of its obligations under this Agreement without prior written of SCC. This Agreement shall be binding upon and inure to the benefit of SCC and Purchaser and each of their legal representatives, successors and assigns.

SCC warrants its products to be free of defects in materials and workmanship under normal use and service for a period of one (1) year from the date of delivery.

This warranty is extended only to the original purchaser for use of the Goods. It does not cover normal wear parts such as plastic tongs, tong holders, tong cables, bag holders, or acrylic dividers.

General Conditions. All service labor and/or parts charges are subject to approval by SCC. Contact the Customer Service Department in writing or call 231-798-8888.

All claims must contain the following information: (1) model & serial code number of equipment; (2) the date and place of installation; (3) the name and address of the agency which performed the installation; (4) the date of the equipment failure; and (5) a complete description of the equipment failure and all circumstances relating to that failure.

Once the claim has been determined to be a true warranty claim by SCC's Customer Service Department, the following procedure will be taken: (1) replacement parts will be sent at no charge from SCC on a freight prepaid basis; (2) reimbursement for service labor will be paid if the following conditions have been met— (a) prior approval of service agency was awarded from the Customer Service Department; and (b) an itemized statement of all labor charges incurred is received by the Customer Service Department. The cost of the service labor reimbursement will be based on straight time rates and reasonable time for the repair of the defect.

If problems occur with any compressor, notify SCC's Customer Service Department immediately. Any attempt to repair or alter the unit without prior consent from the Customer Service Department will render any warranty claim null and void. This warranty and protection plan does not apply to any condensing unit or any part thereof which has been subject to accident, negligence, misuse, or abuse, or which has not been operated in accordance with the manufacturer's recommendations or if the serial number of the unit has been altered, defaced, or removed.

Limit of Liability. The limit of liability of SCC toward the exchange cost of the original condensing unit, F.O.B. SCC, Norton Shores, MI, of each motor-compressor assembly replaced during the warranty shall not exceed manufacturer's current established wholesaler's exchange price and in no case shall the labor of removing or replacing the motor-compressor or parts thereof be the responsibility of SCC.